



Dust Control and Loading Systems Inc

Leaders in Innovative Bulk Loading Systems Design

SV Slide Gate Valve

SLIDE GATE VALVE

DCL's Model SV Slide Gate Valves are designed to shut off product flow from outlets of storage bins, silos, conveyors, and other discharge points handling dry bulk materials.

These rugged heavy duty slide gate valves are available in standard sizes ranging from 6 inches to 36 inches square. Sizes larger than 36 inches, rectangular, and special configurations including dual opposing blade and dewatering designs are available on a custom build basis.

A choice of construction materials allow handling of all types of products and applications; fine, granular, lumpy, abrasive, corrosive, or sanitary.

FEATURES

The valve frame is constructed from heavy duty 3/16 inch steel with a hardened blanchard ground blade which rides on cam rollers or solid guides. Actuation of Slide Gate Valves can be accomplished in many ways; pneumatically for fast action, hydraulically for power, electrically for precise positioning, and manually for maintenance and flow control.

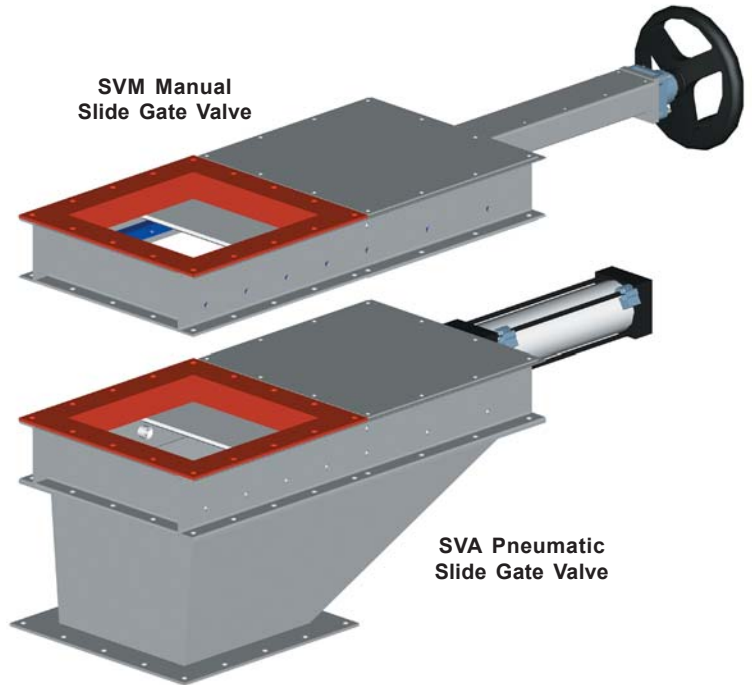

Blade seals are selected according to the material being handled and are available to suit any application. A molded urethane inlet liner provides an ideal blade seal when handling granular products. Additional frame seals are available and should be used when handling fine dusty material. Adjustable seals are also available to virtually eliminate the need for seal replacement. These seals are adjusted from the outside of the valve frame, which makes it unique to the industry.

All SV Slide Gate Valves are equipped with a dust tight transition unless mounted directly above another valve. This transition is recommended when handling fine dusty material.

ULTIMATE FLOW CONTROL PACKAGE

The ultimate flow control package consists of a manually actuated and a powered Slide Gate Valve. With this configuration you can preset product flow with the manual valve and use the powered valve as a shut off.

In the case of product maintenance or equipment failure you can manually shut off the flow valve and service any equipment beneath it.

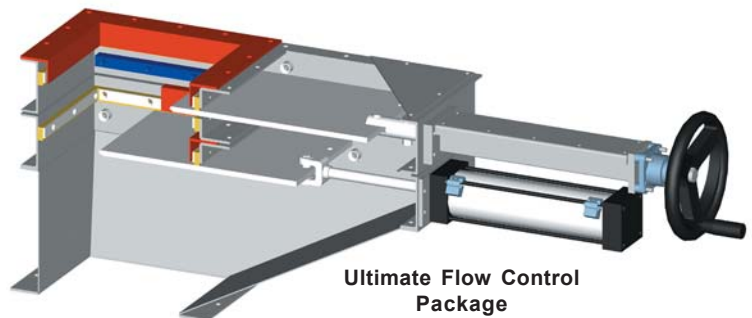

Po Box 125
08660 Ance Road

Dust Control and Loading Systems Inc
Charlevoix, Michigan 49720
www.dclinc.com or info@dclinc.com

Tele: 800-748-0563
Fax: 231-547-3343

PUBc-0502-SV

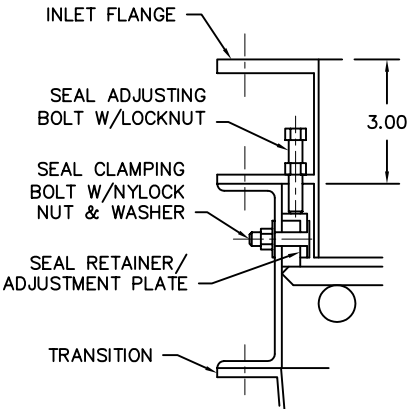

| MODEL | A | B | C | D | E | G | H | J | K | L | M | N | P | S | EST WGT |
|-------|-------|-------|-------|-------|-------|------|-------|-------|---|------|-------|----|-------|------|---------|
| SVA06 | 6.00 | 11.19 | 5.56 | 17.81 | 23.38 | 4.25 | 8.00 | 6.00 | 2 | 5.00 | 10.00 | 6 | 7.31 | 0.38 | 83 LB* |
| SVA08 | 8.00 | 13.19 | 6.56 | 20.81 | 27.38 | 4.25 | 9.00 | 8.00 | 2 | 6.00 | 12.00 | 6 | 9.56 | 0.38 | 112 LB* |
| SVA10 | 10.00 | 15.19 | 7.56 | 23.81 | 31.38 | 4.25 | 10.00 | 10.00 | 2 | 7.00 | 14.00 | 6 | 11.69 | 0.38 | 130 LB* |
| SVA12 | 12.00 | 17.19 | 8.56 | 26.81 | 35.38 | 4.25 | 11.00 | 12.00 | 4 | 4.00 | 16.00 | 8 | 14.00 | 0.38 | 162 LB* |
| SVA14 | 14.00 | 19.50 | 9.75 | 29.63 | 39.38 | 5.25 | 12.00 | 14.00 | 4 | 4.50 | 18.00 | 8 | 16.00 | 0.50 | 214 LB* |
| SVA16 | 16.00 | 21.50 | 10.75 | 32.63 | 43.38 | 5.25 | 13.00 | 16.00 | 4 | 5.00 | 20.00 | 8 | 18.00 | 0.50 | 252 LB* |
| SVA18 | 18.00 | 23.50 | 11.75 | 35.63 | 47.38 | 5.25 | 14.00 | 18.00 | 4 | 5.50 | 22.00 | 8 | 20.00 | 0.50 | 286 LB* |
| SVA20 | 20.00 | 25.50 | 12.75 | 38.63 | 51.38 | 5.25 | 15.00 | 20.00 | 4 | 6.00 | 24.00 | 12 | 21.75 | 0.50 | 326 LB* |
| SVA22 | 22.00 | 27.50 | 13.75 | 41.63 | 55.38 | 5.25 | 16.00 | 22.00 | 4 | 6.50 | 26.00 | 12 | 23.75 | 0.50 | 390 LB* |
| SVA24 | 24.00 | 29.81 | 15.00 | 44.63 | 59.63 | 6.25 | 17.00 | 24.00 | 4 | 7.00 | 28.00 | 12 | 25.88 | 0.75 | 491 LB* |
| SVA30 | 30.00 | 36.00 | 18.00 | 53.88 | 71.88 | 6.25 | 21.00 | 30.00 | 5 | 6.75 | 33.75 | 16 | 32.38 | 0.75 | 680 LB* |
| SVA36 | 36.00 | 42.00 | 21.00 | 62.88 | 83.88 | 6.25 | 24.00 | 36.00 | 5 | 8.00 | 40.00 | 16 | 38.38 | 0.75 | 904 LB* |

OPTIONAL
ADJUSTABLE
SEAL PACKAGE -
CROSS SECTION -
3X SCALE

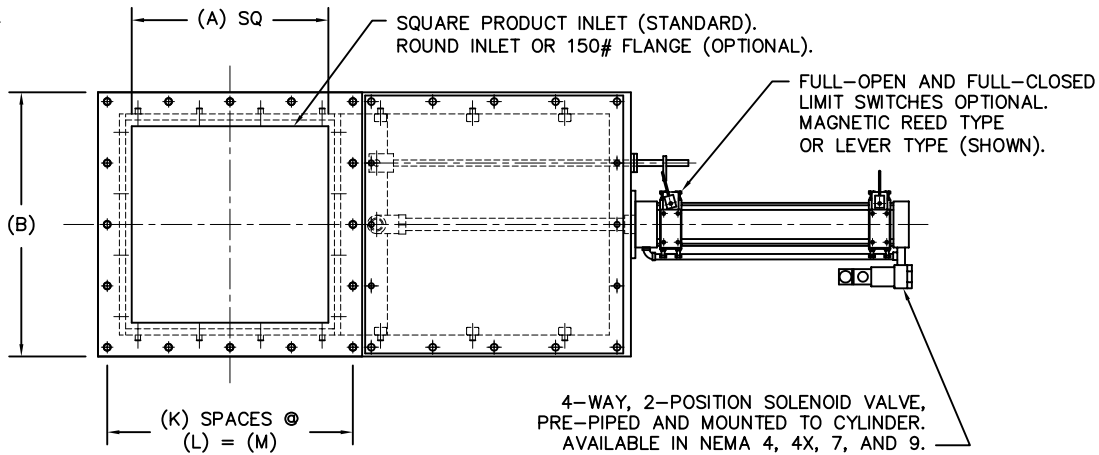

4-WAY, 2-POSITION SOLENOID VALVE,
PRE-PIPED AND MOUNTED TO CYLINDER.
AVAILABLE IN NEMA 4, 4X, 7, AND 9.

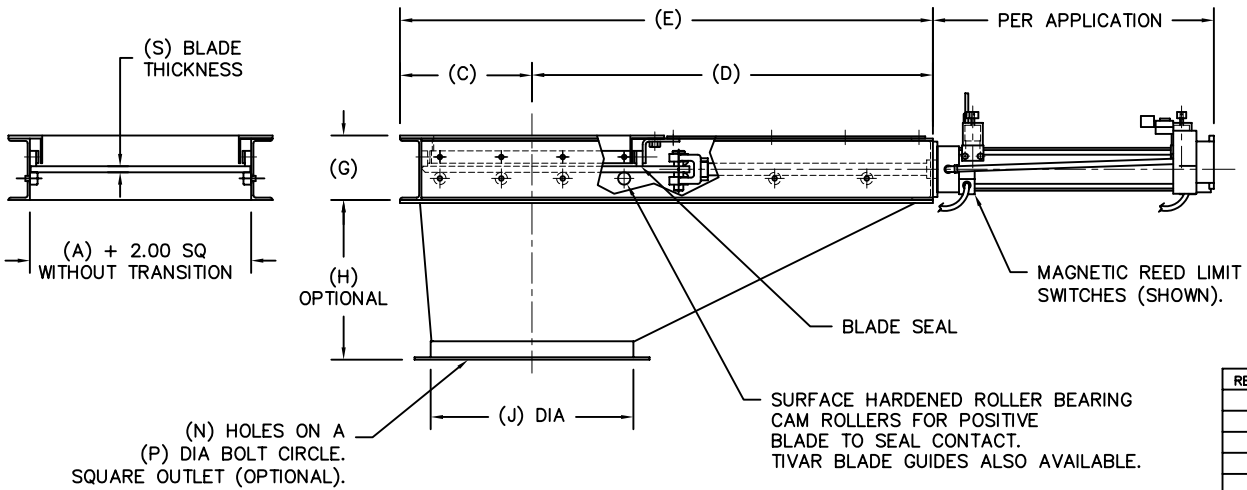

(N) HOLES ON A
(P) DIA BOLT CIRCLE.
SQUARE OUTLET (OPTIONAL).

GENERAL NOTES:

- ALL INDUSTRIAL VOLTAGES AVAILABLE FOR ELECTRICAL COMPONENTS.
- GATE BLADE CONSTRUCTION IS MILD STEEL. ABRASION RESISTANT OR STAINLESS STEEL IS OPTIONAL.
- AVAILABLE BLADE SEALS ARE URETHANE, 3M WIPER BAR, SILICONE, OR VITON.
- DUST TIGHT TRANSITION IS A RECOMMENDED OPTION ON ALL GATE ASSEMBLIES. ONE TRANSITION IS PROVIDED WHEN MAINTENANCE GATE IS MOUNTED TO POWER GATE.
- OPTIONAL DUST TIGHT TRANSITION CONSTRUCTION IS MILD STEEL. ABRASION RESISTANT OR STAINLESS STEEL IS OPTIONAL.
- DIMENSION (H) AND (J) CAN BE VARIED TO SUIT APPLICATION.
- METAL SURFACES ARE POWER TOOL CLEANED, PRIMED, AND FINISHED WITH INDUSTRIAL ENAMEL.
- FULL-OPEN AND FULL-CLOSED LIMIT SWITCHES ARE OPTIONAL, AND ARE AVAILABLE IN NEMA 4, 4X, 7, AND 9.
- LENGTH AND CAPACITY OF ACTUATOR TO BE DETERMINED UPON APPLICATION.
- SPECIFICATIONS AND/OR DIMENSIONAL DATA ARE SUBJECT TO CHANGE. CONSULT DCL FOR CERTIFIED DRAWINGS.
- 150# INLET FLANGE OR ADJUSTABLE 3M SEALS WILL INCREASE DIMENSION (G) BY 2.75.
- *ESTIMATED WEIGHTS DO NOT INCLUDE ACTUATOR, TRANSITION, OR ELECTRICAL COMPONENTS.

| REV | DATE | BY | DCL SPECIALISTS IN ADVANCED DESIGN LOADING SYSTEMS | | P.O. BOX 125 CHARLEVOIX, MICHIGAN 49720 (231) 547-5600 |
|-----|----------|-----|--|-------------------|--|
| | | | TOLERANCES UNLESS OTHERWISE SPECIFIED | FRACTIONAL: 1/16" | DECIMAL: .06 |
| | | | | ANGULAR: 1/2" | |
| | | | DRAWN BY: TLC | SCALE: NONE | |
| | | | CHECKED BY: ENG | DATE: 10-06-92 | |
| | | | TITLE: SV SLIDE GATE VALVE (PNEUMATIC) | | DRAWING No: SVA-10001 |
| A | 10-12-01 | TLC | | | |

*** FOR SIMILAR CONFIGURATIONS REFER TO DRAWINGS; SVE-10001, SVH-10001, SVM-10001