

Box Type Tru-Balance



●
●
●
●
●
●
●
●

**Great
Western
Manufacturing**

Box Type Tru-Balance

The original Tru-Balance sifter is custom designed and built for screening any dry, free-flowing product ranging in size from 1/4" to 400 mesh. It provides a gentle, gyratory sifting motion that is considered to provide the most accurate separations. The machine includes the dust-tight rotating sieve housing mounted in a sanitary tubular steel drive frame. Depending on the application, the sifter can be typically configured for up to six separations.

The gyratory sifting motion is created by the unique Great Western Tru-Balance drive mechanism that straddles the sifter's center of gravity with counterweights and perfectly counterbalances the rotating sieve housing. This

system minimizes foundation requirements and even is available in a ceiling suspended arrangement that allows equipment to be located directly beneath it.

Many sieve construction options are available which include stainless steel or plastic lamination of the standard hardwood sieve, easy to maintain and exchange lift out screen trays, and an all stainless steel sieve. These options, plus many others, coupled with the flexibility in separations and the sifter's large capacity, make the Box Type Tru-Balance sifter the most versatile sifter available in the processing industries.



Feature Overview

- Each machine individually custom engineered to match your requirements.
- Gyrotory motion provides gentle sifting action and proper material stratification that results in accurate separations.
- Unique Great Western "Tru-Balance" drive achieves perfect balance and vibration-free performance. This balance is accomplished by straddling the sifter's center of gravity with counterweights that offset the rotating sieve housing.
- High capacity. Models available each using from four to fourteen sieve frames in four different sieve sizes providing from 10 to 127 ft² of screening area.
- Stacked sieve frames allow the screen area to be matched and accurately allocated to each application.
- Adaptable to a wide range of products, capacities, number of separations and screen sizes.
- Sanitary construction. Crevice free, dust tight, sieve compartment constructed of kiln dried maple and birch panels provides the maximum in fatigue strength and durability with a minimum of weight.
- Sieve box with standard exterior semi-gloss lacquer or with Hammertone enamel finish. Interior lined with stainless steel or plastic laminate for sanitation and abrasion resistance.
- Sieves secured with standard manual rack and pinion system or pneumatic sieve compression system.
- Crankshafts and counterweights are mounted to the rugged tubular drive frame with heavy-duty pillowblock bearings. The drive and motor are readily accessible on the sifter frame.
- The standard speed is 263 rpm with a 2-5/8" circle of gyration. For bulky products a 3-1/2" circle of gyration at 206 rpm is available.
- Floor supported or ceiling suspended arrangements.
- Every unit is test run and balanced prior to shipment.
- Easy installation.

Dimensions

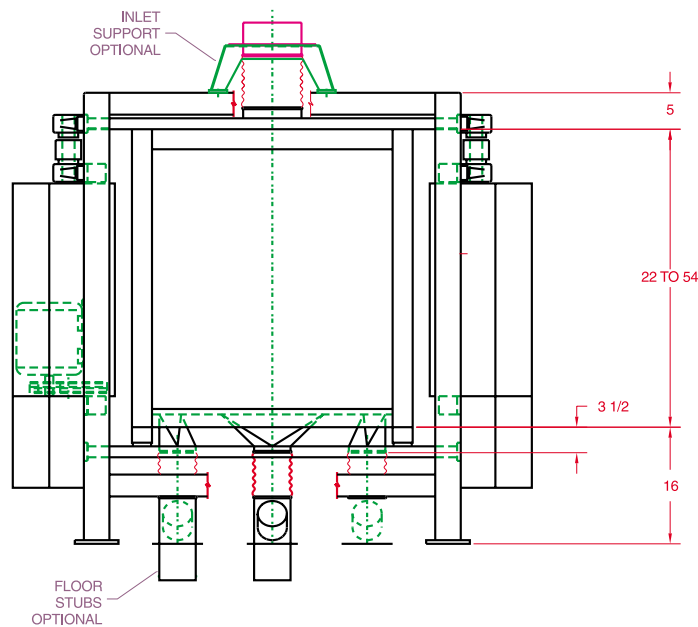
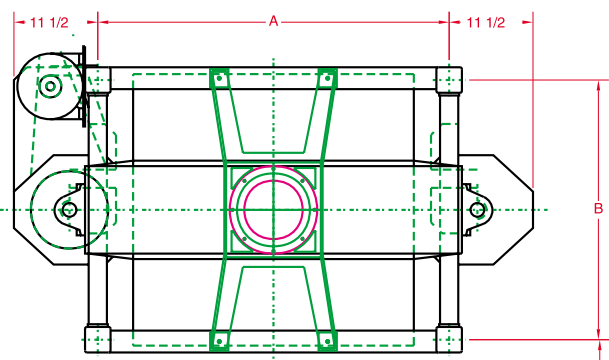

Notes:

- Model 400 series machines use 2 motors.
- Normal motor location is back left-hand corner.
- Shown with optional inlet thimble and outlet floor stubs.

ALLOWANCE FOR SIEVE REMOVAL

FLOOR STUBS OPTIONAL

Model	111	211 or 221	212 or 222	321	322	431	432
Motor(s)	1 @ 1 HP	1 @ 1½ HP	1 @ 1½ HP	1 @ 1½ HP	1 @ 1½ HP	2 @ 1½ HP	2 @ 1½ HP
Sieve Size	24-11/16"	30-7/8"	30-7/8"	30-7/8 x 40-7/8	30-7/8 x 40-7/8	40-7/8"	40-7/8"
Circle	2-5/8"	2-5/8"	3-1/2"	2-5/8"	3-1/2"	2-5/8"	3-1/2"
A	39-5/16"	48-3/16"	51-1/2"	48-3/16"	51-1/2"	48-7/16"	48-7/16"
B	30-1/2"	35-5/8"	35-5/8"	45-5/8"	45-5/8"	46-1/8"	46-1/8"
C	25"	31"	31"	41"	41"	41"	41"

Our pneumatic sieve compression system simplifies your sanitation and maintenance.



- Sifter can be opened, sieves completely removed and maintained, and then reassembled in minutes...with the turn of a key and without special tools. Downtime is minimized.
- The sieve stack is inserted in the machine and nested against sieve guides. The door is secured, aligning the sieves and securing their horizontal position. With the turn of a key the pneumatic sieve compression system lowers the internal press top frame.
- The pneumatic sieve compression controls include an indicator lens to verify the proper position of the compression system. No electrical connections required for the compression controls.
- The pneumatic sieve compression system provides uniform and constant sieve compression while the machine is in operation. This continuous compression reduces sieve frame and gasket wear, reducing the possibility of leakage.



Our horizontal gyratory motion is gentle. It reduces product degradation and is superior to designs using vibratory or centrifugal action.

- Vibratory designs bounce materials vertically which shortens the time they are in contact with the screen and reduces efficiency. Oversized elongated particles pass through the screen when they are upended impairing separation quality.
- Our gentle gyratory sifting action is less severe than centrifugal sifters. Separation of near sized particles is more precise and the risk of fracturing oversize impurities and forcing them through the screen is diminished.

Our stacked screen construction offers many advantages over single deck screening equipment.



- Vertically nested sieves will conserve your valuable plant floor space while offering you maximum grading flexibility. (From four to fourteen frames.)
- Multiple screen frames allow you to proportion the sifting surface of each specific mesh size for highly efficient grading of material.
- Depending on the application, the Box Type Tru-Balance sifter can be typically configured for up to six separations.
- Smaller frames and screens are easier to handle, maintain, exchange and store than large unwieldy single bed screens.
- Smaller screens are less likely to sag and form pockets that collect material. Loose screens lead to the disturbance of product stratification and poor cleaner performance.

Indicative Sifter Configuration and Product Flow

Raw material from inlet deflected to head end of sieve #1

Oversize from sieve #1 exit sifter.

Thrus of sieve #1 fall to sieve #2.

Overs from sieve #2 fall to sieve #3.

Thrus of sieve #2 fall to pan, exit side of sieve.

Thrus of sieves #2 & #3 flow onto sieve #4.

Thrus of sieve #4 fall to pan, exit side of sieve.

Thrus of sieve #5 fall to pan, exit side of sieve.

Thrus of sieve #6 join thrus of sieves #4 & #5. They flow onto sieve #7.

Thrus of sieve #7 fall to pan, exit side of sieve.

Thrus of sieve #8 fall to pan, exit side of sieve.

Thrus of sieve #9 fall to pan, exit side of frame. Joined by thrus from sieves #7 & #8 they exit the sifter.

Oversized material (Overs of sieve #1)

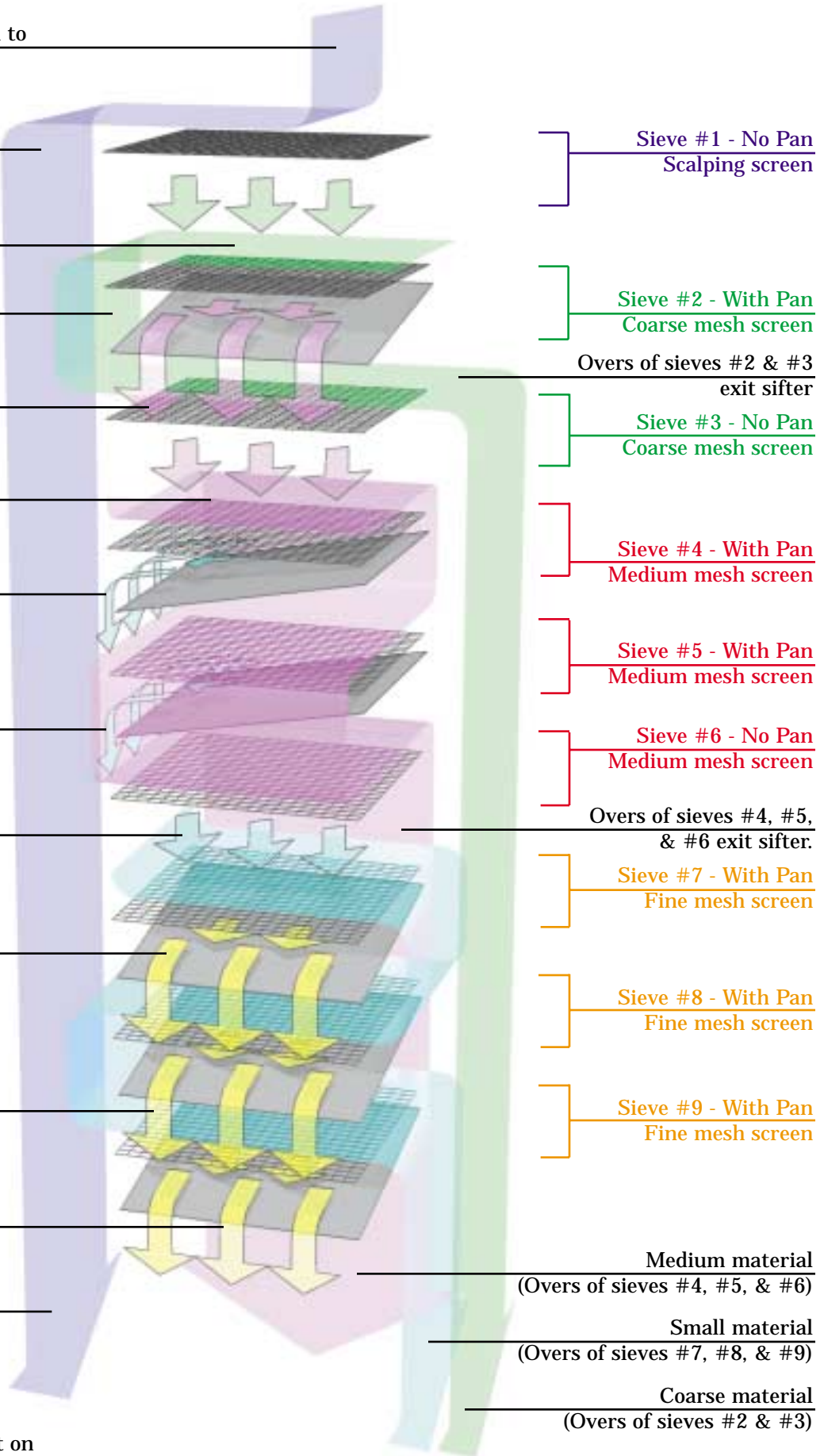

Sieve #1 - No Pan
Scalping screen

Sieve #2 - With Pan
Coarse mesh screen

Overs of sieves #2 & #3
exit sifter

Sieve #3 - No Pan
Coarse mesh screen

Sieve #4 - With Pan
Medium mesh screen

Sieve #5 - With Pan
Medium mesh screen

Sieve #6 - No Pan
Medium mesh screen

Overs of sieves #4, #5,
& #6 exit sifter.

Sieve #7 - With Pan
Fine mesh screen

Sieve #8 - With Pan
Fine mesh screen

Sieve #9 - With Pan
Fine mesh screen

Medium material
(Overs of sieves #4, #5, & #6)

Small material
(Overs of sieves #7, #8, & #9)

Coarse material
(Overs of sieves #2 & #3)

Flow for illustrative purpose only.
Number of separations dependent on
specific application requirements.

Agitator/Blenders

Designed for efficient flour bleaching or enrichment addition in flour mills or blending facilities. The Agitator/Blender is built for long-lasting, dependable service. Three different capacity sizes, built in four different arrangements, allow the machine to be tailored to your specific requirements.



Stream Dividers

Great Western Stream Dividers are the ideal choice for precision division of a single gravity-flow product stream into two to twelve separate streams. The housing and internal turnhead are built from sanitary and durable stainless steel mounted in a tubular steel frame for floor or ceiling installation. Standard models or custom designed units to suit any requirement.

Sampl-Sifters

Sample size sifter is widely used in the cereal processing industry to determine break release, monitor sifting performance, and to perform other quality control testing. Operated with a standard single phase motor and controlled with an adjustable built-in electronic timer, the Sampl-Sifter is available in a table top version or installed in a work table.



Screen Stretchers

Designed to stretch clothing for uniform and consistent tensions on sieve or purifier frames. They offer non-contact stretching and screen elongation control. Two different pneumatic models each feature horizontal stretching without contact with the sieve tray/frame during the primary stretching phase. Our manual stretcher is a reliable economical solution.



Free Testing Service

Great Western maintains a complete testing laboratory to evaluate product samples and make equipment recommendations. Testing will determine how your product handles and what difficulties might be encountered. Test results state area requirements and serve as a guide in determining the optimum equipment size and specifications. There is no charge or obligation for this service.

Frames,
Cleaners,
Clothing
and More!

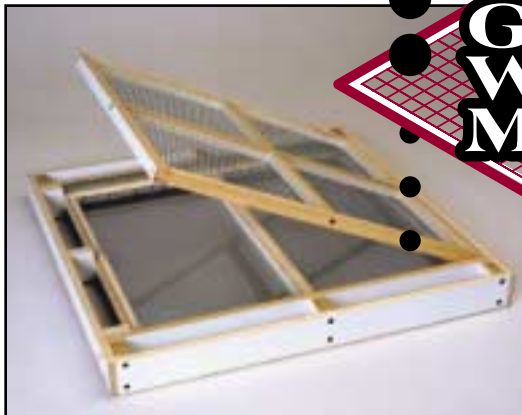

**Great
Western
Manufacturing**