



# SPM

## SUSPENDED PERMANENT MAGNET

### TRAMP MTL 11C (1/99)



\*Photo represents product at date of publication. SPM is shown here with Self-Cleaning Option.

#### **BENEFITS:**

- Protect Processing Equipment from Ferrous Metal Damage
- Improve Product Purity

#### **SIZE AVAILABILITY:**

- Width from 18" to 66"
- 10-5/8" High by 33" Long

#### **INTRODUCTION:**

IMI's permanent magnets offer superior strength and reliability and are designed for separation of ferrous metal from a variety of belt conveyed products. Their heavy industrial design and construction make them ideal for use in foundry, recycling, tire shredding, wood chip, and demolition applications.

#### **FEATURES:**

- Powerful deep reaching magnetic circuit design to penetrate heavy product burdens.
- Similar or greater in strength to many small electromagnets.
- Uniform magnetic field across belt width for full coverage.
- Long magnetic field for extended magnetic exposure.
- Continuously operates at peak magnetic efficiency.
- No operating cost (manual clean units)
- Stainless steel housing
- Industrial welded construction
- Four rigid lift lugs for easy suspension

#### **OPTIONAL FEATURES:**

- Cross-Belt or In-Line magnet configurations
- Stainless steel slider plate
- Manual pull slider plate - roller guided design for easy, quick removal of collected metal.
- Slider plate with hand crank cleaning option
- Self-Cleaning belt and drive package for continuous metal removal from the magnet.
- Cladded belt with 3/16" stainless steel cladding
- Vulcanized belt with vulcanized cleats & splice
- Special stainless steel guarding
- 380/50Hz motors
- Explosion proof motors

#### **SPECIAL CONSIDERATIONS:**

The removal of tramp metal can create many challenges and is dependent upon many factors. These include product size, density, moisture, tramp metal geometry, orientation, magnet suspension height, entrapment by large product pieces, location in the burden, and many others. **Let IMI help you assess your application and solve your metal separation needs with a properly selected magnet.**

**IMI Is Represented By Air Process Systems & Conveyors Co., Inc.**

774 Burr Oak Drive • Westmont, Illinois 60559 • Phone: 630.887.0770 800.822.0771

Fax: 630.887.0771 • Email: Sales@AirProcessSystems.com

**Web: [www.AirProcessSystems.com](http://www.AirProcessSystems.com)**



**SPM SPECIFICATIONS (Self-Cleaning):**

- Ceramic grade 8 magnet material
- All stainless steel magnet box
- 4 pad eyes
- 2-5Hp - 240/480 3 phase motor
- 3/8" thick rubber belt with 5 cleats
- Heavy C-channel
- Class II reducer
- Crowned head & tail pulleys
- External expansion tank

**SPM DIMENSIONS (Self-Cleaning):**

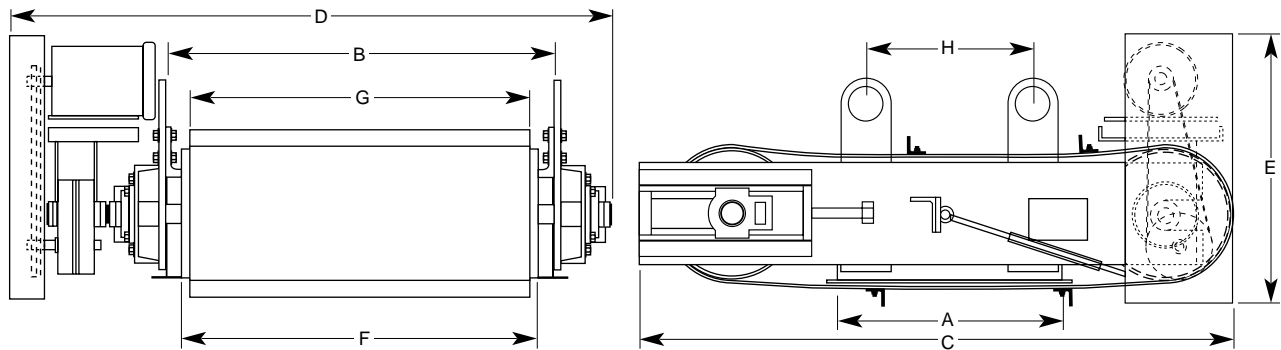

Note: All dimensions are stated in inches.

\*Dimensions representative of product at date of publication. If dimensions are critical, call for up-to-date changes.

Cross Belt SPM Self-Cleaning	Magnet Dimensions	Overall Length	Overall Width	Overall Height	Pulley Width	Belt Width	Pad-Eye Centers	Motor H.P.	Approx Weight
	A x B	C	D	E	F	G	H		Lbs.
SPM24SC	24" x 38"	62"	54"	32"	38"	36"	18"	2	1,800
SPM30SC	30" x 38"	68"	54"	32"	38"	36"	24"	2	2,100
SPM36SC	36" x 38"	74"	54"	32"	38"	36"	30"	2	2,400
SPM42SC	42" x 38"	80"	54"	32"	38"	36"	36"	2	2,800
SPM48SC	48" x 38"	86"	60"	32"	38"	36"	42"	5	3,200
SPM54SC	54" x 38"	92"	60"	32"	38"	36"	48"	5	3,500
SPM60SC	60" x 38"	98"	60"	32"	38"	36"	54"	5	3,900
SPM66SC	66" x 38"	104"	60"	32"	38"	36"	60"	5	4,200

In-Line SPM Self-Cleaning	Magnet Dimensions	Overall Length	Overall Width	Overall Height	Pulley Width	Belt Width	Pad-Eye Centers	Motor H.P.	Approx Weight
	A x B	C	D	E	F	G	H		Lbs.
SPM24SCL	33" x 26"	42"	72"	32"	26"	24"	27"	2	1,800
SPM30SCL	33" x 32"	48"	72"	32"	32"	30"	27"	2	2,100
SPM36SCL	33" x 38"	54"	72"	32"	38"	36"	27"	2	2,400
SPM42SCL	33" x 44"	60"	72"	32"	44"	42"	27"	2	2,800
SPM48SCL	33" x 51"	73"	72"	32"	51"	48"	27"	5	3,200
SPM54SCL	33" x 57"	79"	72"	32"	57"	54"	27"	5	3,400
SPM60SCL	33" x 63"	85"	72"	32"	63"	60"	27"	5	3,900
SPM66SCL	33" x 69"	91"	72"	32"	69"	66"	27"	5	4,200

**SPM SPECIFICATIONS & DIMENSIONS (Manual Clean Models):**

- Ceramic grade 8 magnet material
- All stainless steel magnet box
- 4 pad eyes
- All welded construction

Note: All dimensions are stated in inches.

\*Dimensions represent product at date of publication. If dimensions are critical, call for up-to-date changes.

In-Line SPM Manual Clean	Magnet Width	Magnet Length	Magnet Height	Overall Width	Overall Length	Pad-Eye Centers	Approx Weight
	J	K	L	M	N	P	Lbs.
SPM18	15"	30"	10.62"	18"	33"	14"	860
SPM24	21"	30"	10.62"	24"	33"	20"	1,200
SPM30	27"	30"	10.62"	30"	33"	26"	1,540
SPM36	33"	30"	10.62"	36"	33"	32"	1,881
SPM42	39"	30"	10.62"	42"	33"	38"	2,248
SPM48	45"	30"	10.62"	48"	33"	44"	2,570
SPM54	51"	30"	10.62"	54"	33"	50"	2,910
SPM60	57"	30"	10.62"	60"	33"	56"	3,250
SPM66	63"	30"	10.62"	66"	33"	62"	3,590

