



ROTARY AIRLOCK FEEDERS



HEAVY DUTY
DROP-THRU

SIDE ENTRY HEAVY DUTY DROP-THRU

FEATURES:

- Offset inlet and discharge
- "V" type taper on throat inlet
- Larger shaft diameters than competition

BENEFITS

- Provides optimum product flow
- Minimizes product shearing and degradation
- Assures maximum torque delivery

INDUSTRIES WHERE USED

- Plastic
- Mining
- Chemical
- Baking
- Food

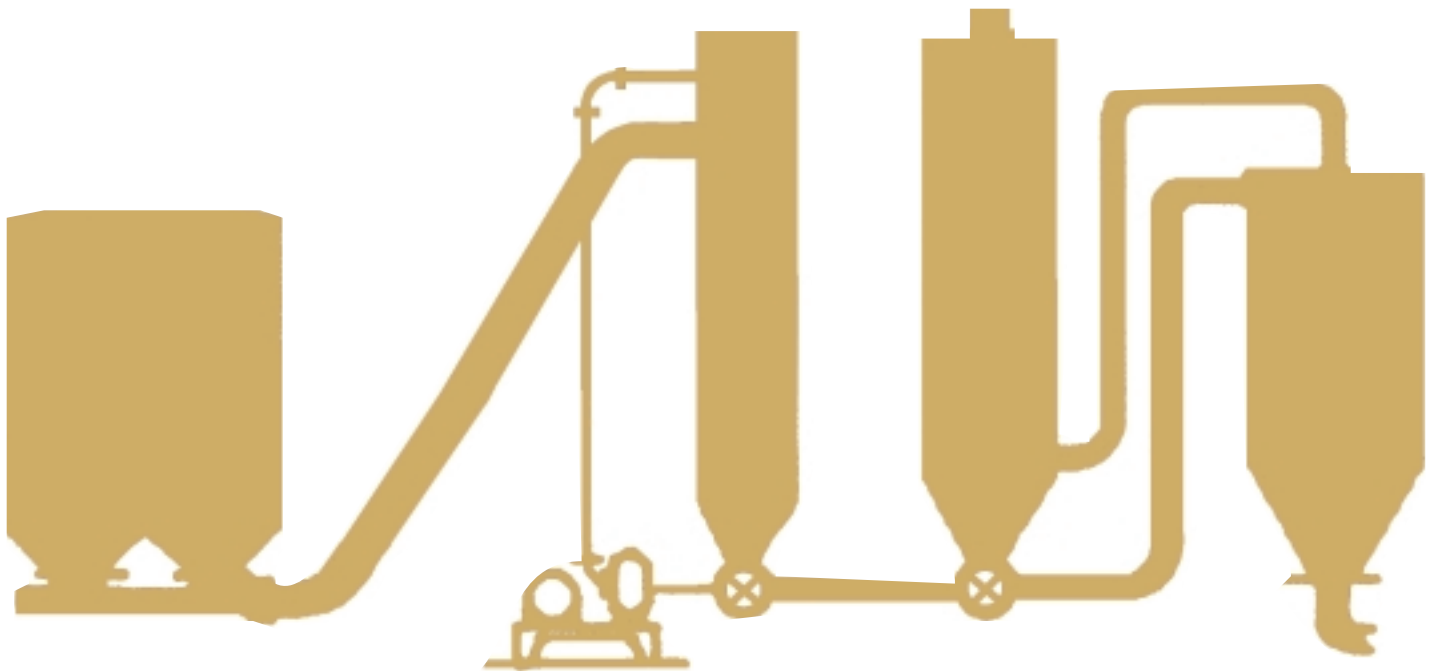

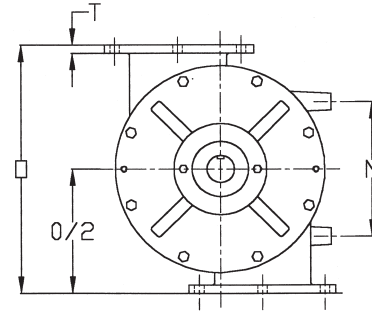
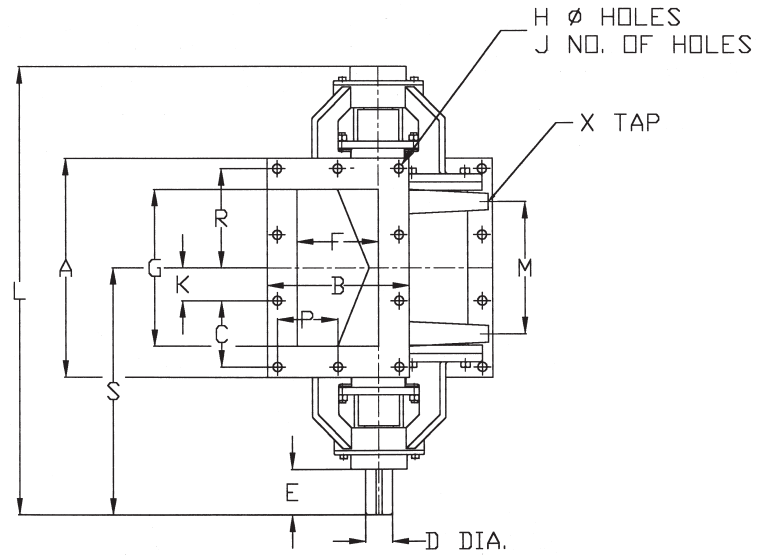

Dimensions (In Inches)
HEAVY DUTY, SIDE ENTRY, DROP-THRU SERIES

SIZE	A	B	C	D	E	F	G	H	J	K	L	M	N	O	P	R	S	T	W†	X
6 x 6	9 ¹ / ₂	6 ³ / ₄	-	1 ¹ / ₈	2 ³ / ₈	3 ¹ / ₂	5 ¹ / ₂	7 ¹ / ₁₆	6	1 ⁷ / ₈	20 ¹ / ₁₆	4 ⁵ / ₁₆	5 ⁵ / ₈	10	2 ⁷ / ₈	4 ¹ / ₄	11 ³ / ₁₆	3 ³ / ₈	1 ¹ / ₄ X 1 ¹ / ₈ X 2	3 ³ / ₈ -16
8 x 8	11	7 ¹ / ₂	-	1 ³ / ₈	2 ¹¹ / ₁₆	4	7 ¹ / ₂	7 ¹ / ₁₆	6	2 ¹ / ₂	21 ¹³ / ₁₆	6	7 ¹ / ₄	12	3	4 ⁷ / ₈	12 ¹ / ₄	1 ¹ / ₂	5 ¹ / ₁₆ X 5 ⁵ / ₃₂ X 2	3 ³ / ₈ -16
10 x 10	13 ¹ / ₄	8 ³ / ₄	4	1 ⁵ / ₈	2 ¹ / ₂	5	9 ¹ / ₂	9 ¹ / ₁₆	10	2	26 ³ / ₄	8	8 ¹ / ₈	15	3 ³ / ₄	6	14 ⁵ / ₈	1 ¹ / ₂	3 ³ / ₈ X 3 ¹ / ₁₆ X 2	1 ¹ / ₂ -13
12 x 12	16 ¹ / ₄	11	4 ⁷ / ₈	2	3 ¹ / ₂	6	11 ¹ / ₄	9 ¹ / ₁₆	10	2 ⁷ / ₁₆	34 ¹ / ₄	9 ³ / ₄	10 ¹ / ₂	18 ¹ / ₄	4 ¹¹ / ₁₆	7 ⁵ / ₁₆	18 ⁷ / ₈	5 ⁵ / ₈	1 ¹ / ₂ X 1 ¹ / ₄ X 3	1 ¹ / ₂ -13
14 x 14	19	12	4 ¹ / ₄	2 ³ / ₁₆	4 ¹ / ₄	7	14	9 ¹ / ₁₆	12	4 ¹ / ₄	38 ¹ / ₂	12	9 ¹ / ₄	21	5	8 ¹ / ₂	21 ³ / ₈	5 ⁵ / ₈	1 ¹ / ₂ X 1 ¹ / ₄ X 4	1 ¹ / ₂ -13
16 x 16	22	14	5	2 ¹ / ₂	4	8	16	9 ¹ / ₁₆	12	5	41 ¹ / ₄	14	12	24	6	10	22 ⁵ / ₈	5 ⁵ / ₈	5 ⁵ / ₈ X 5 ¹ / ₁₆ X 4	1 ¹ / ₂ -13
18 x 18	24	15	5 ¹ / ₄	2 ¹ / ₂	4	9	18	11 ¹ / ₁₆	12	5 ¹ / ₄	43 ¹ / ₄	16	12	27	6	10 ¹ / ₂	23 ⁵ / ₈	1	5 ⁵ / ₈ X 5 ¹ / ₁₆ X 4	1 ¹ / ₂ -13
22 x 22	28	17	5	2 ¹ / ₂	4	11	22	11 ¹ / ₁₆	16	2 ¹ / ₂	47 ¹ / ₄	20	12	31	7 ¹ / ₂ ‡	12 ¹ / ₂	25 ⁵ / ₈	1	5 ⁵ / ₈ X 5 ¹ / ₁₆ X 4	1 ¹ / ₂ -13

‡ No hole on center line-holes straddle center line.
 † Key way in shaft-width x depth x length.



Wm W. Meyer & Sons, Inc.
 8261 Elmwood Ave. P.O. Box 105
 Skokie, Illinois 60077
 Phones: 847-673-0312 • FAX: 847-673-5564
 E-mail: wmsales@theramp.net
 website: <http://www.wmmeyer.com>

YOUR LOCAL REPRESENTATIVE